

SIEMENS



Level measurement guide: for complete level solutions

[siemens.com/level](https://www.siemens.com/level)



Answers for industry.

Intelligence. Reliability. Accuracy. Siemens level measurement.

Monitoring water levels in open channels. Tracking the amount of grain in a silo. Measuring oil in a tank. Simply put, level measurement tells you how much material is at a given location.

With the knowledge that no single technology can address the needs of all industrial applications, Siemens provides a complete range of level measurement devices.

Ultrasonics. Radar. Guided wave radar. Capacitance. Point level. Gravimetric. Hydrostatic.

Reliable. Easy to use. With convenient remote monitoring displays and industrial communication options. All backed by Siemens global support network, providing experienced sales and technical assistance when and where you need it. Complementing our level technology are Siemens analytics, automation, and drives for industries around the globe.

Millions of applications worldwide, with one common theme: together, these diverse level measurement technologies make us Siemens.



Table of Contents

Level measurement selector	4
Ultrasonics	6
Transducer selection	8
Radar for solids	10
Radar for liquids and slurries	12
Guided wave radar	14
Hydrostatic	15
Continuous capacitance	16
Gravimetric	18
Point level	20
Remote monitoring & digital displays	24
Training, sales & support	26
Communications	27

SITRANS LUT400

Welcome to the evolution of ultrasonics. Prepare yourself. With world-leading accuracy, unparalleled ease of use, setup in under a minute, and the customer-driven features you asked for, the SITRANS LUT400 series ultrasonic controllers have arrived. Making your work simpler and providing the reliability you need. These compact, single point controllers excel at continuous level monitoring and control in liquids, solids, or slurry applications in a wide range of industries. Three models make up the series: SITRANS LUT420 Level and Volume Controller, SITRANS LUT430 Level, Pump, Volume, and Flow Controller, and SITRANS LUT440 High Accuracy Open Channel Monitor (OCM), which also provides a full suite of advanced level, volume, and pump controls.



SITRANS LUT400

- Industry-leading accuracy – SITRANS LUT400's ± 1 mm (0.04") accuracy gives you confidence in your measurements
- Easy to use – local user interface with four-button programming, menu-driven parameters, and Wizard support for key applications
- Quick to configure – graphical Quick Start Wizards guide you during setup
- Next generation Sonic Intelligence – improved performance in noisy environments thanks to digital receiver technology
- Consistently high performance – patented digital receiver technology ensures reliability even in the harshest environments
- Compatibility with Siemens Echomax transducers – operating range of 0.3 to 60 meters (1 to 200 ft), depending on transducer

Meet the ultrasonics family

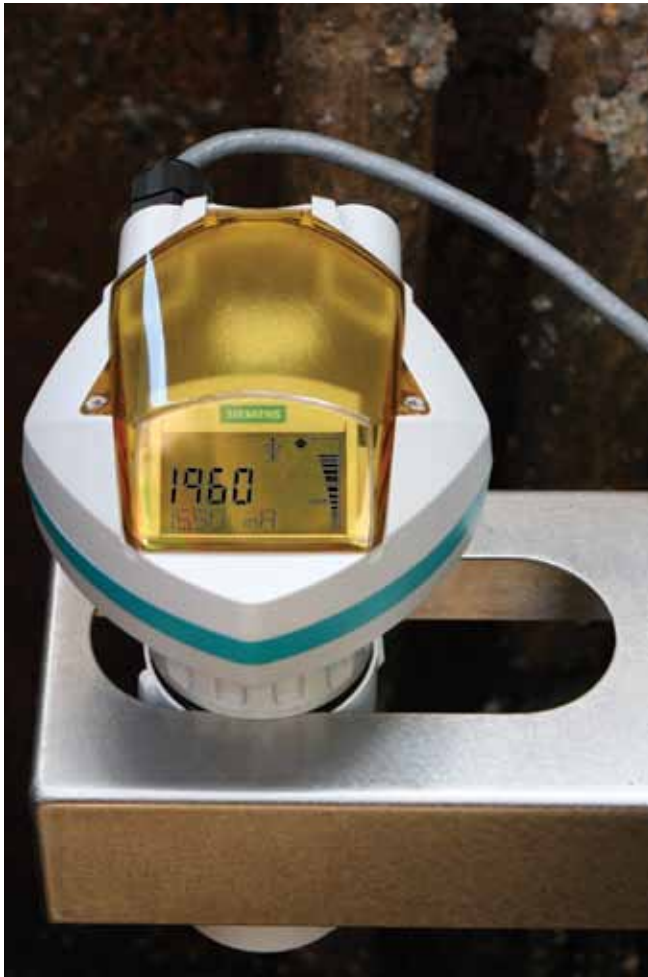

Decades of experience

Siemens' range of ultrasonic controllers and transmitters are a non-contacting technology requiring little to no maintenance compared to other devices. They are a cost-effective solution for short- to long-range applications of liquids, slurries, and solids. Siemens ultrasonics feature our patented Sonic Intelligence echo processing, delivering accurate measurement you can depend on. Ideal applications include water/wastewater monitoring and pumping, inventory management, and truck load-outs.



	SITRANS LUT400	MultiRanger/ HydroRanger 100/200	SITRANS Probe LU	The Probe
Order No.	7ML5050	7ML5033/7ML5034	7ML5221	7ML1201
	SITRANS LUT400 series controllers are compact, single point, long range ultrasonic controllers for continuous level or volume measurement of liquids, slurries, and solids, and high accuracy monitoring of open channel flow.	MultiRanger/HydroRanger are versatile short- to medium-range ultrasonic single and multi-vessel level monitor/controllers for virtually any application in a wide range of industries.	SITRANS Probe LU is a 2-wire loop-powered level measurement transmitter – ideal for measuring your storage vessels, filter beds, and open channel flow in the water and wastewater, food, and chemical industries.	The Probe is a short-range integrated ultrasonic level transmitter – ideal for liquids and slurries in your open or closed vessels.
Range	0.3 to 60 m (1 to 200 ft), transducer and material dependent	0.3 to 15 m (1 to 50 ft), transducer and material dependent	<ul style="list-style-type: none"> • 6 m model: 0.25 to 6 m (0.8 to 20 ft) • 12 m model: 0.25 to 12 m (0.8 to 39 ft) 	0.25 to 5 m (0.8 to 16 ft)
Key features	<ul style="list-style-type: none"> • Patented digital receiver for enhanced performance and reliability in noisy applications • Intuitive ease of use • Advanced pump, alarm, and flow control features with three relays • Integrated datalogger • Real time clock with daylight saving time and energy-saving algorithms 	<ul style="list-style-type: none"> • Range of models for simple level measurement or pump control to more complex for differential level, open channel measurement, and advanced pump control, alarming, and gate control • Simple setup and programming with infrared handheld programmer or via SIMATIC PDM • Auto False-Echo Suppression to avoid false echoes from fixed obstructions 	<ul style="list-style-type: none"> • Superior functionality and plug-and-play performance • Programming via PC software or infrared handheld programmer • IP68 rated • Level, volume, and flow measurement • -40 to 85 °C (-40 to 185 °F) • PVDF or ETFE transducer for chemical compatibility 	<ul style="list-style-type: none"> • Easy to install and maintain • Easy two-button programming • PVDF transducer for chemical compatibility • -40 to 60 °C (-40 to 140 °F) • IP65 rated
Communications or outputs	<ul style="list-style-type: none"> • HART: EDDs for SIMATIC PDM, Emerson AMS Device Manager, and Field Communicator 375, plus SITRANS DTM for FDTs • USB: Integrated web browser for local programming from an intuitive web-based interface 	<ul style="list-style-type: none"> • RS-485 with Modbus RTU or ASCII • Compatible with SIMATIC PDM via Modbus RTU <p>Option</p> <ul style="list-style-type: none"> • SmartLinx cards for PROFIBUS DP, Allen-Bradley Remote I/O, DeviceNet 	<ul style="list-style-type: none"> • HART or PROFIBUS PA • EDD for SIMATIC PDM for remote configuration and diagnostics • FDT such as PACTware or Fieldcare via SITRANS DTM (HART version only) 	<ul style="list-style-type: none"> • 4 to 20 mA output <p>Option</p> <ul style="list-style-type: none"> • Alarm relay

Echomax transducers

Siemens Echomax ultrasonic level transducers provide trouble-free, reliable performance. Our non-contacting transducers are impervious to dust, moisture, vibrations, flooding, and high temperatures. With the ability to detect submergence – when paired with a submergence shield – and an active face to reduce material buildup, these transducers are a perfect fit for a range of industrial applications. Siemens transducers are easy to install and require little to no maintenance.



With every transducer from Siemens, you get:

- Sonic Intelligence (when paired with a Siemens controller) – our field-proven echo processing algorithms guarantee the most reliable performance possible.
- Unmatched beam angle – stronger pulse and sensitivity in a compact beam make our ultrasonics transducers the most powerful in the industry.
- Ease of installation – Siemens' wide range of mounting brackets and accessories provide the right installation package for any application.
- Sales and support in your neighborhood – our extensive global coverage means conveniently located sales and support.



	XRS-5	ST-H	XPS-10 XPS-15 (standard and F models*)	XPS-30 XPS-40	XCT-8 XCT-12
	Liquids		Liquids/Solids		
Order No.	7ML1106	7ML1100	7ML1115, 7ML1170, 7ML1118, 7ML1171	7ML1123, 7ML1127	7ML1132, 7ML1136
Max. range	8 m (26 ft)	10 m (33 ft)	XPS-10: 10 m (33 ft) XPS-15: 15 m (50 ft)	XPS-30: 30 m (98 ft) XPS-40: 40 m (130 ft)	XCT-8: 8 m (26 ft) XCT-12: 12 m (40 ft)
Min. range	0.3 m (1 ft)	0.3 m (1 ft)	0.3 m (1 ft)	XPS-30: 0.6 m (2 ft) XPS-40: 0.9 m (3 ft)	0.6 m (2 ft)
Max. temp	65 °C (149 °F)	CSA/FM model: 73 °C (163 °F) ATEX model: 60 °C (140 °F)	95 °C (203 °F)	95 °C (203 °F)	XCT-8: 145 °C (293 °F) Sanitary: 125 °C (260 °F) XCT-12: 145 °C (293 °F)
Min. temp	-20 °C (-4 °F)	CSA/FM model: -40 °C (-40 °F) ATEX model: -20 °C (-4 °F)	-40 °C (-40 °F) F: -20 °C (-4 °F)	-40 °C (-40 °F)	-40 °C (-40 °F)
Typical applications	<ul style="list-style-type: none"> Flumes Weirs Filterbeds 	<ul style="list-style-type: none"> Chemical storage Liquid tanks 	XPS-10 <ul style="list-style-type: none"> Dusty solids Slurries Liquids XPS-15 <ul style="list-style-type: none"> Deep wet wells Solids 	<ul style="list-style-type: none"> Powders Pellets Solids Deep wet wells 	XCT-8 <ul style="list-style-type: none"> Hot acids Slurries Food XCT-12 <ul style="list-style-type: none"> Hot liquids Slurries
Beam angle -3db	10°	12°	XPS-10: 12° XPS-15: 6°	6°	XCT-8: 12° XCT-12: 6°
Enclosure	<ul style="list-style-type: none"> PVDF copolymer and CSM face IP68 rated Options <ul style="list-style-type: none"> CPVC Flange PTFE face with CPVC Flange Submergence detection with shield 	<ul style="list-style-type: none"> ETFE PVDF IP68 rated 	<ul style="list-style-type: none"> PVDF IP68 rated Options <ul style="list-style-type: none"> PVDF with CPVC Flange PTFE face with CPVC Flange Submergence detection with shield 	<ul style="list-style-type: none"> PVDF IP68 rated Options <ul style="list-style-type: none"> PVDF with CPVC flange PTFE face with CPVC Flange 	XCT-8 <ul style="list-style-type: none"> PVDF IP68 rated Options <ul style="list-style-type: none"> 4" sanitary connection XCT-12 <ul style="list-style-type: none"> PVDF IP68 rated
SITRANS LUT400 series	●	●	●	●	●
MultiRanger 100/200	●	●	●		●
Hydro-Ranger 200	●	●	●		●

All Siemens transducers have one or more of the following approvals: CE, CSA, ATEX, SAA, ABS, and Lloyd's Register of Shipping.
*FM Class 1 Div 1 approved.

Radar for solids

SITRANS LR560 is the easiest to use solids radar transmitter on the market. With a high frequency of 78 GHz, 4 degree narrow beam, and short wavelength, it performs reliably on solids material from practically any installation location.

For extremely low dielectric, low density powders, the 25 GHz SITRANS LR460 is the preferred solution. Featuring a horn antenna with an 8 degree beam, the 4-wire FMCW SITRANS LR460 has proven itself in thousands of applications. Siemens solids radar transmitters easily tackle dusty environments and are not affected by temperature changes.



SITRANS LR560

- 78 GHz radar transmitter allows for measurement through intense dust
- An exceptionally narrow 4° beam angle can cope with complicated silo geometry
- Sealed lens cavity is highly resistant to dust buildup
- Easy to install and configure with Quick Start Wizard
- Small size fits most silo nozzles
- Two measurement ranges: 40 m (131 ft) and 100 m (328 ft)



	SITRANS LR560	SITRANS LR460
Order No.	7ML5440	7ML5426
	2-wire, 78 GHz FMCW radar level transmitter for continuous monitoring of solids.	4-wire, 25 GHz FMCW radar level transmitter for continuous monitoring of solids. Ideal for materials with extremely low dielectric properties.
Range	<ul style="list-style-type: none"> • 40 m (131 ft) Option • 100 m (328 ft) 	100 m (328 ft)
Process temperature	-40 to 200 °C (-40 to 392 °F)	-40 to 200 °C (-40 to 392 °F)
Process pressure	Up to 3 bar g (43.5 psi g) option	0.5 bar g (7.25 psi g) max.
Key features	<ul style="list-style-type: none"> • Graphical Quick Start Wizard for easy and fast setup • Push buttons or optional Intrinsically Safe infrared handheld programmer • Air purge connection included Option • Aimer flange for optimizing readings in the silo cone area 	<ul style="list-style-type: none"> • Intrinsically Safe infrared handheld programmer • Extremely high signal yields high performance (high signal-to-noise ratio) • Quick Start Wizard for setup Option • PTFE antenna cover • Air purge connection
Communications and Configurations	<ul style="list-style-type: none"> • HART, PROFIBUS PA, or FOUNDATION Fieldbus • Enhanced EDD for SIMATIC PDM, Emerson AMS Device Manager, SITRANS DTM (for PACTware), 375/475 handheld, for configuration and diagnostics 	<ul style="list-style-type: none"> • HART or PROFIBUS PA • Enhanced EDD for SIMATIC PDM for configuration and diagnostics

Radar for liquids and slurries

SITRANS LR250 is your first choice for liquid level measurement in storage and process vessels to 20 meters (66 ft). SITRANS LR400 offers high performance even on low dielectric media. For process vessels which may include turbulence, buildup, or foam, SITRANS LR200 is the best choice. Its low frequency better suits this environment and functions reliably in applications up to 20 meters (66 ft).

For low-cost level measurement, SITRANS Probe LR offers a small process connection and operates at a low frequency. It can be used on liquids and slurries up to 20 meters (66 ft). Simple configuration and programming make this transmitter a cost-effective solution.



SITRANS LR250

- Easy to install – small horn and narrow beam allows installation practically anywhere on your vessel
- Quick to configure – Quick Start Wizard guides you during setup
- Application flexibility – new PVDF threaded antenna makes it ideal for harsh process conditions, as well as SIL 2 rating for applications demanding functional safety
- Process Intelligence – advanced echo processing for unparalleled performance
- Reliable and accurate – extremely high signal and low noise yields high performance, even with low dielectric media



	SITRANS LR250	SITRANS Probe LR	SITRANS LR200	SITRANS LR400
Order No.	7ML5431	7ML5430	7ML542x	7ML5421
	2-wire, 25 GHz pulse radar level transmitter for continuous monitoring of liquids and slurries in storage/process vessels.	2-wire, 6 GHz pulse radar level transmitter for continuous monitoring of liquids in storage vessels.	2-wire, 6 GHz pulse radar level transmitter for continuous monitoring of liquids. Ideally suited for more complex process vessels.	4-wire, 24 GHz FMCW radar level transmitter for continuous monitoring of liquids including extremely low dk to 1.6.
Range	20 m (66 ft)	20 m (66 ft)	20 m (66 ft)	50 m (164 ft)
Process temperature	-40 to 200 °C (-40 to 392 °F) at process connection with FKM O-ring	-40 to 80 °C (-40 to 176 °F)	-40 to 200 °C (-40 to 392 °F)	-40 to 200 °C (-40 to 392 °F) Option: up to 250 °C (482 °F)
Process pressure	Up to 40 bar g (580 psi g), process connection type dependent	Up to 3 bar g (43.5 psi g)	Up to 40 bar g (580 psi g), process connection type dependent	Up to 40 bar g (580 psi g), process connection dependent
Key features	<ul style="list-style-type: none"> • Process Intelligence – advanced echo processing for unparalleled performance • Graphical user interface (LUI) • Quick Start Wizard and display diagnostics • Threaded PVDF antenna for aggressive conditions characteristic of acids, alkalis, and other corrosive chemicals • Complies with IEC 61508/61511 standard for functional safety (SIL 2) 	<ul style="list-style-type: none"> • Process Intelligence – advanced echo processing for unparalleled performance • Patented, shielded, and hermetically sealed polypropylene antenna/process connection; 100 mm (4") shield standard • Rotating head aligns with conduit for easy wiring Options <ul style="list-style-type: none"> • 250 mm (10") shield length 	<ul style="list-style-type: none"> • Process Intelligence – advanced echo processing for unparalleled performance • Graphical user interface (LUI) • Quick Start Wizard and display diagnostics Options <ul style="list-style-type: none"> • Multiple antenna designs for application flexibility • 250 mm (10") shield length • Purging (self-cleaning) for buildup protection 	<ul style="list-style-type: none"> • High signal-to-noise ratio • Operates on low dk media (example LPG applications)
Communications & Configurations	<ul style="list-style-type: none"> • HART, PROFIBUS PA, or FOUNDATION Fieldbus • Enhanced EDD for SIMATIC PDM, Emerson AMS, SITRANS DTM (for PACTware), 375/475 handheld, for configuration and diagnostics 	<ul style="list-style-type: none"> • HART • EDD for SIMATIC PDM for configuration and diagnostics 	<ul style="list-style-type: none"> • HART or PROFIBUS PA • Enhanced EDD for SIMATIC PDM, Emerson AMS, SITRANS DTM (for PACTware), 375/475 handheld, for configuration and diagnostics 	<ul style="list-style-type: none"> • HART or PROFIBUS PA • SIMATIC PDM for configuration and diagnostics

Guided wave radar

SITRANS LG200 is Siemens 2-wire guided wave radar transmitter for short- to medium-range level, level/interface, and volume measurement of liquids, slurries, and bulk solids. Its many antenna configurations make it possible to measure numerous complex applications, even ammonia, chlorine, high temperature/pressure, or cryogenics.



	SITRANS LG200
Order No.	7ML1300/7ML130X
	2-wire, guided wave radar transmitter for short- to medium-range level, level/interface, and volume measurement of liquids and solids.
Range	22.5 m (75 ft)
Process temperature	-196 to 427 °C (-320 to 800 °F)
Process pressure	Full vacuum to 431 bar g (6250 psi g), probe dependent
Key features	<ul style="list-style-type: none"> • Unaffected by change in density and dielectric properties of 1.4 and higher • Accurate to 2.5 mm (0.1") • Extended insertion length – probe lengths up to 22.5 m (75 ft) • Push button configuration or HART communication • Complies with IEC 61508/61511 standard for functional safety (SIL 2) <p>Probe options</p> <ul style="list-style-type: none"> • Coaxial probes for steam, ammonia, overfill, interface, and high pressure/high temperature • Single rod probes (rigid including sanitary or cable) • Twin rod (rigid or cable)
Communications	<ul style="list-style-type: none"> • HART • Enhanced EDD for SIMATIC PDM and 375/475 handheld, for configuration and diagnostics

Hydrostatic

Hydrostatic level measurement with Siemens gauge, absolute, and differential pressure transmitters is a low cost option for direct mounting or mounting with remote seals on tanks and vessels. These instruments can handle extreme chemical and mechanical loads as well as electromagnetic interference. They are widely applied in chemical and petrochemical industries.



	SITRANS P MPS	SITRANS P DSIII	SITRANS P300	SITRANS P500
Order No.	7MF1570	7MF463x	7MF8X3x	7MF56x
	Hydrostatic level transmitter for direct mounting on tanks or vessels.	Hydrostatic level transmitter for mounting with remote seal on open or closed vessels with corrosive or non-corrosive liquids.	Hydrostatic level transmitter for mounting with front flush design or remote seal on open or closed vessels with corrosive or non-corrosive liquids.	Hydrostatic level transmitter for mounting with remote seal on open or closed vessels with corrosive or non-corrosive liquids.
Range	From 0 to 2 mH ₂ O to 0 to 20 mH ₂ O	10 to 30,000 mbar g (0.15 to 435 psi g)	0.01 to 400 bar g (0.15 to 5802 psi g)	1.25 to 1250 mbar (0.5 to 502 in H ₂ O)
Process temperature	-10 to 80 °C (14 to 176 °F)	-40 to 100 °C (-40 to 212 °F)	-40 to 100 °C (-40 to 212 °F)	-40 to 125 °C (-40 to 257 °F)
Process pressure	N/A	32 to 160 bar g (464 to 2325 psi g)	0.01 to 400 bar g (0.15 to 5802 psi g)	1.25 to 1250 mbar (0.5 to 502 in H ₂ O)
Key features	<ul style="list-style-type: none"> • Compact stainless steel enclosure and sensor • Easy installation <p>Options</p> <ul style="list-style-type: none"> • Intrinsically Safe • Special measuring ranges: 0 to 1 mH₂O to 0 to 200 mH₂O • Cable length up to 1000 m (3280 ft) 	<ul style="list-style-type: none"> • With remote seals up to 400 °C (752 °F) • Self-diagnostic elements for parameterization <p>Options</p> <ul style="list-style-type: none"> • Intrinsically Safe • Explosion proof and flame proof • SIL 2/3 approved • Corrosion-resistant diaphragm and process connections • Range of different process connections 	<ul style="list-style-type: none"> • With remote seals up to 400 °C (752 °F) • With front flush design up to 200 °C (392 °F) • Self-diagnostic elements for parameterization <p>Options</p> <ul style="list-style-type: none"> • Intrinsically Safe • Corrosion-resistant diaphragm and process connections • Range of different process connections 	<ul style="list-style-type: none"> • With remote seals up to 400 °C (752 °F) • Diagnostics for customized configuration • Excellent long-term stability • Short response times <p>Options</p> <ul style="list-style-type: none"> • Intrinsically Safe • Explosion proof and flame proof • Corrosion-resistant diaphragm and process connections
Communications	N/A	<ul style="list-style-type: none"> • HART • PROFIBUS PA/PROFIsafe • FOUNDATION Fieldbus 	<ul style="list-style-type: none"> • HART • PROFIBUS PA • FOUNDATION Fieldbus 	<ul style="list-style-type: none"> • HART

Capacitance



Tried and tested for a wide range of applications, Siemens inverse frequency shift capacitance continuous level transmitters are suitable for liquids, solids, and interface applications. Siemens capacitance instruments use active-shield technology to ensure true and accurate level readings are recorded from the material surface.

SITRANS LC300 and SITRANS LC500 are ideal for standard and industrial applications in the chemical, hydrocarbon processing, and food and beverage industries.



	SITRANS LC300	SITRANS LC500
Order No.	7ML567x	7ML551x / 7ML552x
	Inverse frequency shift capacitance level transmitter for liquids and solids applications; ideal for standard industrial applications in chemical, hydrocarbon processing, food and beverage.	Inverse frequency shift capacitance level and interface transmitter for extreme and critical process conditions, such as oil and liquefied natural gas (LNG), aggressive chemicals, and vapors.
Range	Rod: 0.3 to 5.5 m (1 to 18 ft) Cable: 1 to 25 m (3 to 82 ft)	Rod: 0.3 to 5.5 m (1 to 18 ft) Cable: 1 to 35 m (3 to 115 ft)
Process temperature	-40 to 200 °C (-40 to 392 °F)	<ul style="list-style-type: none"> -50 to 200 °C (-58 to 392 °F) -200 to 200 °C (-328 to 392 °F): special order
Process pressure	Up to 35 bar g (511 psi g)	Up to 150 bar g (2175 psi g)
Key features	<ul style="list-style-type: none"> Patented Active-Shield technology Push-button calibration Integrated local display Inverse frequency approach provides high resolution 	<ul style="list-style-type: none"> Patented Active-Shield technology Push-button calibration Integrated local display Full-function diagnostics Inverse frequency approach provides high resolution
Communications	N/A	HART

Gravimetric

Gravimetric level measurement with SIWAREX weighing technology gives you excellent results without ever contacting the material. Load cells combined with SIWAREX electronics determine your product's weight independent of process conditions such as temperature, container shape, material density, shift in the center of gravity, or agitators. Bridging, heaped objects, hopper flow, foam, steam, and dust have no effect on gravimetric measurement.



	SIWAREX U	SIWAREX CS	SIWAREX MS	SIWAREX FTA
Order No.	7MH4950	7MH4910	7MH4930	7MH4900
Typical applications	Basic weighing and force measuring tasks, one or two channel modules available.	Basic weighing and force measuring tasks.	Basic weighing and force measuring tasks.	Automatic and non-automatic weighing, e.g. for production of mixtures, filling, loading, monitoring, and bagging.
Automation system integration	S7-300 (directly or via ET 200M), S7-400 (H), PCS 7 (H) (via ET200M)	S7-400, S7-300 (via ET 200S)	S7-200	S7-300 (directly or via ET 200M), S7-400 (H), PCS 7 (H) (via ET200M)
Accuracy	0.05%	0.05%	0.05%	0.005%
Key features	<ul style="list-style-type: none"> • A versatile weighing module for all simple weighing and force measuring tasks • High resolution of 65,000 parts and an accuracy of 0.05% • Simple Parameterizing with SIWATOOL • Modules can be exchanged without readjusting the scale • Can be used for Ex applications 	<ul style="list-style-type: none"> • A compact weighing module for the Decentral Peripheral System ET200S from SIMATIC • High resolution of 65,000 parts • Universal communication due to the integration in SIMATIC S7 • Extensive diagnostic capabilities • Can be used for Ex applications 	<ul style="list-style-type: none"> • Applicable for measuring tasks like non-automatic weighing machines, fill level monitoring of silos and bunkers, measuring of crane and cable loads • Universal communication due to the integration in SIMATIC S7 • Extensive diagnostic capabilities • Simple parameter definition with the SIWATOOL MS program • Can be used for Ex applications 	<ul style="list-style-type: none"> • A versatile weighing module for e.g. the production of mixtures, filling, loading, monitoring and bagging • Universal communication through the integration in SIMATIC S7 and SIMATIC PCS 7 • Fast dosing with fast communication • Exact dosage switching signals (< 1 msec) • Flexible adjustment for different requirements
Approvals	ATEX 95, FM, cUL _{US} Hazardous Locations			ATEX 95, FM, cUL _{US} Haz. Loc., EU type approval (CE, OIML R76), EU MID (OIML R51, R61, R107)

Precision from a single source – weighing technology from Siemens

With SIWAREX electronics and load cells, not only are you choosing the highest quality in construction, long-lasting performance, and easy integration into your systems, you are also opening the doors to Siemens' comprehensive spectrum of instrumentation.



	SIWAREX WL230	SIWAREX WL230	SIWAREX WL250	SIWAREX WL270	SIWAREX WL280
Order No.	7MH5107	7MH5106	7MH5105	7MH5108/5110/5114	7MH5113
Type	Shear beam	Bending beam	S-Type	Compression	Ring torsion
Typical applications	Container, overhead rail conveyor, and platform scales	Small scale containers and platform scales	Tank weighing, hybrid scales, or suspended container weighing	Containers, hoppers, and vehicle scales	Containers, hoppers, and vehicle scales
Nominal load (E_{max})	0.5 to 5 t	10 to 500 kg	50 kg to 10 t	6 to 280 t	60 kg to 60 t
Accuracy class and maximum scale intervals	C3 to OIML R60; 3,000 intervals	C3 to OIML R60; 3,000 intervals	C3 to OIML R60; 3,000 intervals	C3 to OIML R60; 3,000 intervals WL270 K with 0.1%	C3 to OIML R60; 3,000 intervals
Minimum scale intervals	E _{max} /10,000	E _{max} /6,000 to E _{max} /10,000	E _{max} /7,000 to E _{max} /12,000	E _{max} /9,000 to E _{max} /10,000	E _{max} /16,000 to E _{max} /17,500
Supply voltage	5 to 12 V	5 to 12 V	5 to 12 V	5 to 12 V	5 to 30 V
Nominal characteristic	2 mV/V	2 mV/V	3 mV/V	2 mV/V	1 to 2 mV/V
Degree of protection	IP68	IP68	IP67	IP68 WL270 K IP66	IP66/IP68

Meet the point level family

Siemens level switches detect high, low, and demand levels in solids, including low bulk density applications such as dry powder and fine grain, and in liquid applications, including sticky materials. These switches work independent of material conditions such as vapors, gases, bubbles, or foam.



Our level switches offer superior performance while reducing maintenance, downtime, and equipment replacement cost. Their robust design lasts in harsh and abrasive environments, guaranteeing a long service life and low cost of ownership. They are easy to set up and to connect to any alarm or control system.

Our rotating or vibrating point level switches specialize in low bulk density applications. Standard aluminum enclosures and stainless steel process connections provide exceptional resistance to mechanical forces.

Our unique inverse frequency shift approach to capacitance technology ensures accurate, reliable, and repeatable measurement, even in dusty, turbulent, and vaporous environments or in situations with product buildup. Because even a small level change creates a large and detectable change in frequency, Siemens Pointek CLS series provide excellent resolution while consistently outperforming conventional devices.

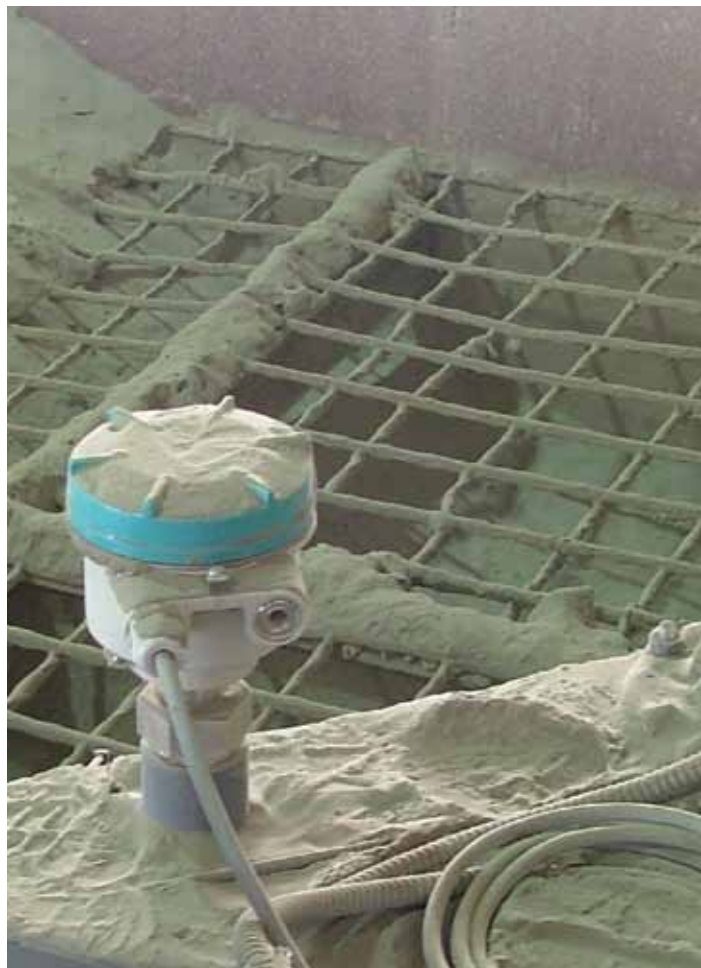

Point level



	SITRANS LVS100	SITRANS LVS200	SITRANS LVL100	SITRANS LVL200	SITRANS LPS200
Order No.	7ML5735	7ML5731-4	7ML5745	7ML5746/7ML5747	7ML5725-8/7ML5730
	Vibrating point level switch for high or low level detection of dry powder, fine grain, and granular bulk solids with densities starting at 60 g/l (3.7 lb/ft ³).	Vibrating point level switch for dry powder, fine grain, and granular bulk solids with densities as low as 5 g/l (0.3 lb/ft ³).	Compact vibrating level switch for liquid and slurry applications such as overflow, high, low, and demand applications, as well as pump protection. It is ideal for use in confined spaces.	Standard vibrating level switch for all liquid and slurry applications such as overflow, high, low, and demand applications, as well as pump protection. For use in SIL-2 applications.	Rotary paddle switch for point level detection of powder and granular solids with bulk densities as low as 15 g/l (0.94 lb/ft ³).
Range	170 mm to 2 m (6.7" to 6.5 ft)	<ul style="list-style-type: none"> Rigid extension: 165 mm to 4 m (6.5" to 13 ft) Extended model 700 mm to 20 m (27.5" to 65 ft) 	Compact insertion length of 40 mm (1.5") for tight spaces	<ul style="list-style-type: none"> Compact insertion length starting at 40 mm (1.5" to 13 ft) for tight spaces Options <ul style="list-style-type: none"> Extension options available up to 4 m (13 ft) 	100 mm to 10 m (4" to 30 ft)
Process temperature	-40 to 150 °C (-40 to 302 °F)	-40 to 150 °C (-40 to 302 °F)	-40 to 150 °C (-40 to 302 °F)	-50 to 250 °C (-58 to 482 °F)	-25 to 600 °C (-13 to 1112 °F)
Process pressure	Up to 10 bar g (145 psi g)	Up to 10 bar g (145 psi g)	-1 to 64 bar g (-14.5 to 928 psi g)	-1 to 64 bar g (-14.5 to 928 psi g)	<ul style="list-style-type: none"> Up to 0.5 bar g (7.25 psi g) Optional up to 10 bar g (145 psi g)
Key features	<ul style="list-style-type: none"> High, low and demand level detection Compact design Top, side, angle, and bottom mount Replaceable electronics 	<ul style="list-style-type: none"> Top, side, angle, and bottom mount Self-cleaning fork Extended and adjustable model up to 20 m (65 ft) Interface model with detection of solids in liquids Best-in-industry lowest density measurement below 5 g/l (0.3 lb/ft³) Unaffected by external vibrations 	<ul style="list-style-type: none"> Test function standard to confirm correct operation Fault monitoring for corrosion, loss of vibration, or line break to the piezo drive Robust design with threaded piezo drive system to prevent failure in aggressive applications 	<ul style="list-style-type: none"> Fault monitoring for corrosion, loss of vibration, or line break to the piezo drive SIL 2 qualified for high level and dry run applications Hygienic process connections Modular design for ease of maintenance 	<ul style="list-style-type: none"> Optional hinged measuring vane for lower densities and mounting through small process connections Five point ingress protection Motor sleep mode during switched state to provide long service life Unique friction clutch mechanism to prevent impact damage from falling process materials



	Pointek CLS100	Pointek CLS200	Pointek CLS300	Pointek CLS500	Pointek ULS200
	7ML5501/7ML5610	7ML5630-4/7ML5640-4	7ML5650-2/7ML5660-2	7ML5601-4	7ML1510
	Compact 2 or 4-wire inverse frequency shift capacitance switch for level detection in constricted spaces, interfaces, solids, liquids, slurries, and foam.	Inverse frequency shift capacitance switch with a high level of chemical resistance; ideal for level detection of interfaces, solids, liquids, slurries, foam, and for simple pump control.	Inverse frequency shift capacitance level switch for detecting solids, liquids, slurries, and interface in demanding conditions of elevated pressures, temperatures, and corrosive and abrasive materials.	Inverse frequency shift capacitance level switch for detecting interfaces, solids, liquids, toxic and aggressive chemicals in critical conditions of extreme temperature and extreme pressure.	Ultrasonic non-contacting switch with two switch points for level detection of bulk solids, liquids, and slurries in a wide variety of industries; ideal for sticky materials.
	100 mm (4") insertion	Rod: 100 mm to 5.5 m (4" to 18 ft) Cable: 1 to 30 m (3 to 98 ft)	Rod: 350 mm to 1 m (14 to 40") Cable: 1 to 25 m (3 to 82 ft)	Rod: 200 mm to 1 m (8 to 40")	<ul style="list-style-type: none"> Liquids: 0.25 m to 5 m (0.8 to 16 ft) Solids: 0.25 m to 3 m (0.8 to 10 ft)
	-30 to 100 °C (-22 to 212 °F)	-40 to 125 °C (-40 to 257 °F) with thermal isolator	-40 to 400 °C (-40 to 752 °F) high temperature version	-60 to 400 °C (-76 to 752 °F) high temperature version	-20 to 60 °C (-5 to 140 °F) if mounted in metal threads
	Up to 10 bar g (145 psi g)	Up to 25 bar g (365 psi g)	Up to 35 bar g (511 psi g)	Up to 150 bar g (2175 psi g)	Atmospheric
	<ul style="list-style-type: none"> Inverse frequency provides high resolution Sensitivity adjustment Level detection independent of tank wall/pipe Options <ul style="list-style-type: none"> Multiple outputs SensGuard for abrasive applications PPS or PVDF probe offerings for wide range of applications IP68 	<ul style="list-style-type: none"> Inverse frequency provides high resolution Level detection independent of tank wall/pipe Multiple outputs Fully adjustable hysteresis and sensitivity settings Options <ul style="list-style-type: none"> SensGuard for abrasive applications PVDF probe options for wide range of applications IP68 Extensions up to 25 m (82 ft) 	<ul style="list-style-type: none"> Inverse frequency provides high resolution Patented Active-Shield technology Multiple outputs Five dip switches for special adjustments e.g. fail safe, high/low Options <ul style="list-style-type: none"> Extensions up to 25 m (82 ft) IP68 Display Profibus PA 	<ul style="list-style-type: none"> Inverse frequency provides high resolution Patented Active-Shield technology Push-button calibration Integrated local display 2-wire loop signal Full-function diagnostics Remote adjustable commissioning / control capabilities via HART Multiple outputs 	<ul style="list-style-type: none"> Easy two button programming Two switch outputs for high-high, high, low, and low-low alarms for pump-up/pump-down control Options <ul style="list-style-type: none"> Flange adapter Sanitary mounting

Remote displays and monitoring

Siemens remote digital displays complement our range of level, flow, pressure, temperature, weighing, and other process devices. SITRANS RD100 is NEMA 4X/IP67 enclosed for indoor and outdoor applications, in hot or cold environments, and in safe or hazardous areas. SITRANS RD200 is a universal input, panel mount, remote digital display for remotely collecting, logging, and presenting data from as many as 100 displays to your local computer. SITRANS RD500 is a remote data manager providing remote monitoring through data logging, web access, and alarming for instrumentation.

SITRANS RD500

- Simple web access – type an IP address in a web browser and immediately access data from remotely installed devices
- Ideal instrumentation accessory – track up to 128 conventional IO instruments remotely
- Easy setup – web application supports out-of-the-box operation
- Flexible communications options – integrated web and FTP server, email, and SMS for alarming
- High capacity datalogger – capacity to store years of data, supporting up to two gigabytes of removable compact flash memory

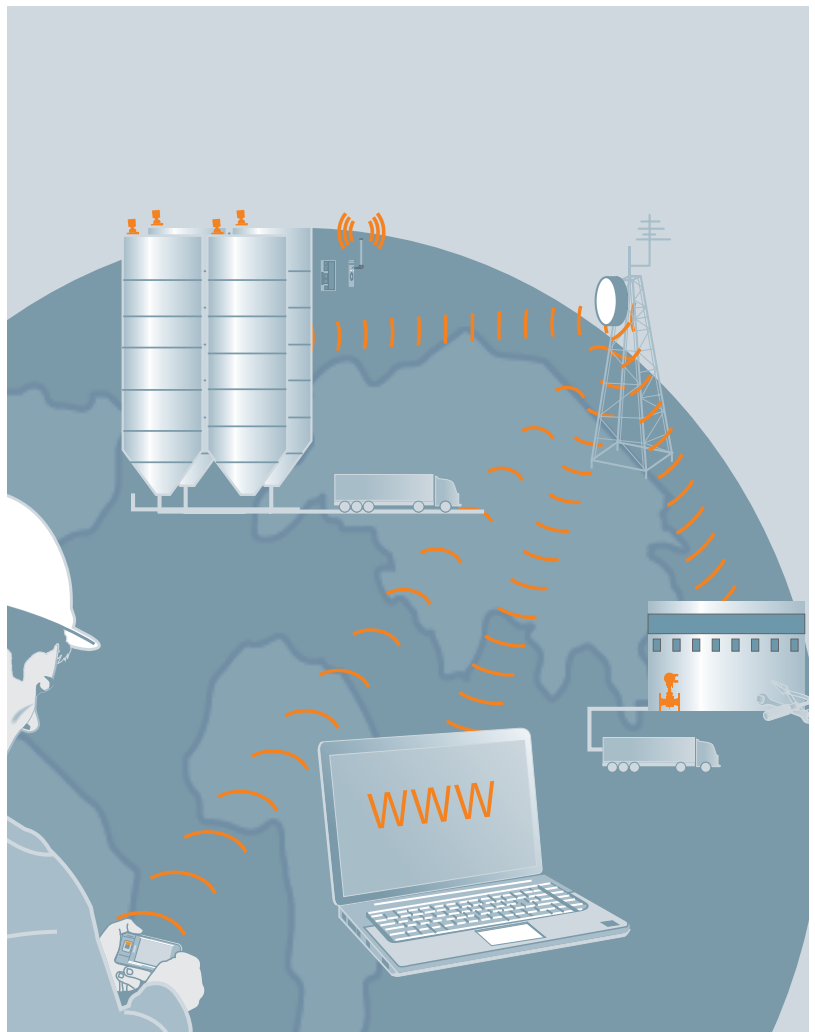

With SITRANS RD500, monitor inventory levels, process, environmental, and remote maintenance applications, and get web access to most types of field instrumentation, including flow, level, pressure, temperature measurement, and weighing.



	SITRANS RD100	SITRANS RD200	SITRANS RD500
Order No.	7ML5741	7ML5740	7ML5750
	2-wire-loop powered enclosed remote digital display for process instrumentation.	Universal input, panel mount, remote digital display for process instrumentation.	Remote data manager for monitoring and data logging, web access, and alarming.
Input types	4 to 20 mA	Universal current, voltage, RTD, thermocouple	0 to 10 V, 0 (4) to 20 mA, RTD, TC, digital and Modbus (RS-485, RS-232)
Power specifications	Nominal 24 V DC max. 30 V DC, 4 to 20 mA	<ul style="list-style-type: none"> Option 1: 85 to 265 V AC, 50/60 Hz; 90 to 265 V DC, 20 W max. Option 2: 12 to 36 V DC, 12 to 24 V AC, 6 W max. 	<ul style="list-style-type: none"> 24 V DC \pm10% 400 mA min. (1 module) 3.5 Amps max. (16 modules) Class 2 or SELV-rated power supply
Digits	3.5 digit display	4 digit display	NA
Key features	<ul style="list-style-type: none"> 2-wire loop-powered Simple two-step configuration Intrinsically Safe, non-incendive Two modes of input allow for easy servicing, with no interruption of loop required Factory calibrated Large display 	<ul style="list-style-type: none"> Easy to read in all conditions Accepts current, voltage, thermocouple and RTD signals Included software supports remote monitoring, programming, data logging alarm acknowledgement Can be used for alarm indication or process control applications Provides power to instrument 24 V DC, 200 mA 	<p>Number of I/O</p> <ul style="list-style-type: none"> Serial Modbus RTU devices 128 conventional I/O RTD/TC 4 to 20 mA/0 to 10 V/digital (optional 16 modules) <p>Communication</p> <ul style="list-style-type: none"> Ethernet, Ethernet TCP/IP, HTML, Modbus TCP, FTP, SMTP <p>Option</p> <ul style="list-style-type: none"> GSM, GPRS, PSTN, 3G <p>Memory</p> <ul style="list-style-type: none"> On-board user memory: 4 MB of non-volatile Flash memory On-board SDRAM: 2 MB Memory card: Compact Flash Type II slot for Type I and Type II cards; 2 GB max.
Enclosure	NEMA 4X/IP67 impact resistant	NEMA 4X/IP65 front panel	High impact plastic and stainless steel; installation category I; Pollution degree 2 IP20
Display visibility	25.4 mm (1") high LED	14 mm (0.56") high LED	Mounting
Operating temperature	-40 to 85 °C (-40 to 185 °F)	0 to 65 °C (32 to 149 °F)	<ul style="list-style-type: none"> Storage temperature: -30 to 70 °C (-22 to 158 °F) Operating temperature: 0 to 50 °C (32 to 122 °F) Humidity: 80% max relative humidity, non-condensing, from 0 to 50 °C (32 to 122 °F)

PI Training

Maximize your skills with factory-certified training

Industry Sector SC PI2 provides a full schedule of Process Instrumentation training opportunities for Siemens employees, channel partners, and customers. The PI Training courses are designed for new sales and service employees to learn the product lines, the technologies, and the applications. The courses are also prerequisites for the advanced technology courses which provide in-depth application training. Designed for hands-on learning, all courses are led by field-tested instructors who combine extensive application and instrumentation knowledge with seasoned training experience. Our PI Training Center is specifically designed to optimize your classroom time. It is fully equipped with application simulation stations, a full range of PI instruments, and complete industrial communication networks.

For current information and schedules, visit our website at:

www.siemens.com/instrumentation/training/canada

Sales and support

Custom engineering

Siemens provides custom-engineered products to solve your special application needs. From material compatibility challenges to unique size requirements, Siemens custom engineering team can help.

Service around the world

Plants must function reliably at all times. Efficient and effective process instrumentation and analytics are an indispensable requirement to this end. You also need to be certain of fast and competent service from your supplier. Siemens is a global company that reacts locally. Whether you require consulting, quick delivery, or installation of new devices, the Siemens network of specialists is available to you around the world, wherever your location.

Service around the clock

Our online support system offers rapid, comprehensive assistance regardless of time or location. From product support to service information, Siemens Industry online support is your first choice – around the clock, 365 days a year.

www.siemens.com/automation/service&support



Join us online!

Get information fast

Siemens offers numerous instructional and promotional videos featuring our level and weighing instruments. View these on YouTube at:

www.youtube.com/thinksiemens

Follow us on twitter (SiemensSensors) and Facebook.

Communication

With Totally Integrated Automation (TIA), Siemens provides a comprehensive, integrated product and system spectrum for the efficient automation of the entire production process.

TIA enables realization of perfectly tailored automation solutions to meet all individual production requirements.

Thanks to the uniquely integrated qualities of TIA, companies are able to optimize their production processes, accelerate time to market, and reduce production costs – while maintaining a high level of investment security and minimizing overall project complexity.

Communication flexibility

Siemens TIA approach offers ease of connection to a DCS system such as SIMATIC PCS 7 using industrial standards. Siemens provides communication flexibility, supporting:

- SIMATIC PDM
- PROFIBUS
- HART
- FOUNDATION Fieldbus
- Model 375 HART field communicator and Emerson AMS
- SmartLinx (cards are available for PROFIBUS DP, Modbus RTU, Allen-Bradley Remote I/O, and DeviceNet)
- FDT Software via SITRANS DTM

Allen-Bradley is a registered trademark of Rockwell Automation. DeviceNet is a trademark of Open DeviceNet Vendor Association (ODVA). HART is a registered trademark of HART Communication Foundation. FOUNDATION Fieldbus is a trademark of The Fieldbus Foundation. Modbus is a registered trademark of Schneider Electric. PACTware is a trademark of PACTware International. PROFIBUS is a trademark of Profibus International. For detailed specifications and a full list of approvals (Intrinsically Safe, Explosion Proof, Non-Sparking, Hazardous Locations, and Sanitary), see www.siemens.com/level.

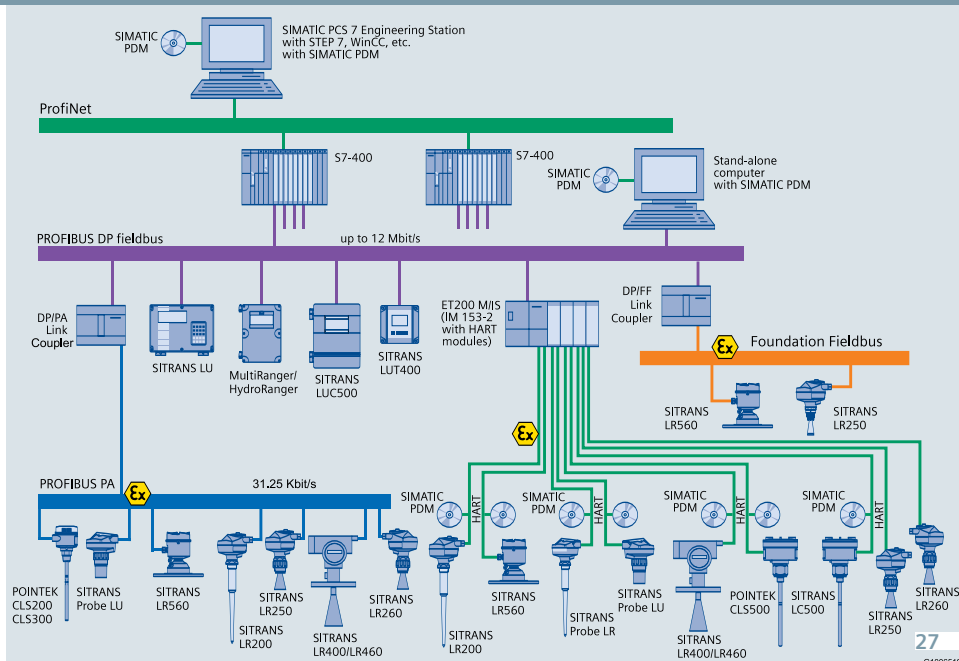

More information:

www.siemens.com/level

www.siemens.com/processautomation

Siemens AG
Industry Sector
Sensors and Communication
76181 KARLSRUHE
GERMANY

www.siemens.com/sensorsystems

Subject to change without prior notice
Order No.: 7ML1996-5MB03
Printed in Canada
© Siemens AG 2012

The information provided in this brochure contains merely general descriptions or characteristics of performance which in case of actual use do not always apply as described or which may change as a result of further development of the products. An obligation to provide the respective characteristics shall only exist if expressly agreed in the terms of contract.

All product designations may be trademarks or product names of Siemens AG or supplier companies whose use by third parties for their own purposes could violate the rights of the owners.